

WECC Wind park

WECC_WP_1

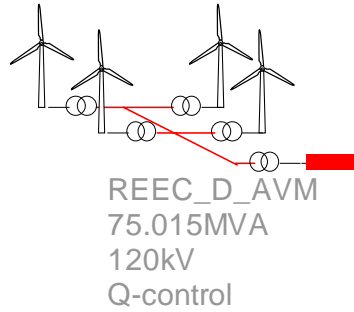

WECC_WT_1

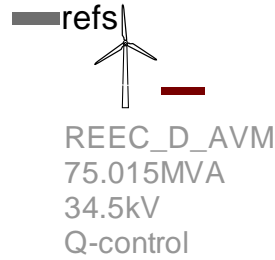

WECC Wind park	1
1 Description	2
2 wind park Pins and Device Mask	4
2.1 wind park pins	4
2.2 Parameters	4
2.2.1 General tab	4
2.2.2 Park Transformer tab.....	4
2.2.3 Inverter Transformer tab.....	5
2.2.4 Mechanical system tab	5
2.2.5 Converter control tab.....	6
2.2.6 Protection tab.....	9
2.2.7 Park controller tab	9
2.2.8 Harmonics tab.....	10
3 WECC Wind Park model	10
3.1 General	10
3.2 Hardware	11
3.3 Mechanical control system	11
3.4 Converter control system.....	13
3.4.1 Computing Variable block.....	14
3.4.2 Generic current loop control.....	15
3.4.3 REEC_D model.....	15
3.4.4 Generic current loop control.....	16
3.4.5 REGC_A	17
3.4.6 REGC_C.....	18
3.5 Inverter protection system block	19
3.5.1 Over/under voltage protections and deep voltage sag detector	19
3.5.2 DC overvoltage protection block	20
3.5.3 Overcurrent protection block.....	21
3.6 Park controller.....	21
3.7 Inverter harmonic model.....	22
4 References.....	23

Hossein Ashourian, Henry Gras, 5/5/2023 5:55 PM

1 Description

This document presents a generic EMTP wind park model. The wind turbine control systems are mainly intended to implement the models suggested by Renewable Energy Modeling Task Force of the Western Electric Coordinating Council (WECC) [1]- [2] in EMTP. Here, it is named the WECC wind park model. Type 3 and type 4 wind turbine generators are modeled. The WECC wind park model contains four main controllers:

- The renewable energy generator controller (REGC),
- The renewable energy electrical controller (REEC),
- The renewable energy plant controller (REPC), and
- The wind turbine mechanical system.

To interfaces the power converter to the external grid, and the converter can be modeled as

- Detailed (DM), in which a detailed circuitry of the power converter is implemented in EMTP including power semiconductors (e.g., IGBT switches), DC bus, measuring filters etc. [3] [4],
- Average-Value (AVM), in which power semiconductor switches are replaced by average value model of the inverter replicating the average response of switching devices, converters and controls [3] [4], or
- a voltage source, in which the direct-current (DC) bus is neglected. The converter/generator controller is developed based on the REGC_C model [1] in EMTP, or
- a current source, in which the DC bus is neglected. The converter/generator controller is model based on the REGC_A model [2] in EMTP.

For DM or AVM, the inverter model is a three-phase grid-connected voltage source converter (VSC). The voltage references for the inverter/converter are calculated by the inner current loops using dq-frame decoupling feed-forward technique [3], [4]. The DC link of the converter is connected a constant DC voltage source.

For REGC_C and REGC_A based models, the converter hardware is modeled with voltage and current sources, respectively. These are mainly developed in EMTP to import the advanced models, to run different control algorithms, and to compare the EMT results from/with ones used in the positive-sequence power system software platforms such as General Electric GE-PSLF, Siemens PTI PSSE, PowerWorld simulator, and PowerTech Labs TSAT. Besides, both balance and unbalance conditions can be simulated in EMTP which is not commonly used in these platforms.

AVM, REGC_C and REGC_A models have the advantage of using much higher the simulation integration time step compared to the detailed model (DM), therefore significantly reducing the simulation time. A time-step of 10 μ s or smaller for the DM, a time-step of 20 μ s or smaller for the AVM, and a time-step of 100 μ s or smaller for the REGC_C and REGC_A models can be used in the EMTP simulations.

REEC controller represents the outer control loops of the inverter. It receives the active and reactive power reference from the REPC module, with feedback of terminal voltage and generator power output, calculates reference active and reactive currents, and sends real and reactive current commands to the inner current loops or the REGC controllers. In EMTP, REEC_D model is implemented [2]. This is the most recent inverter control model developed by WECC, which contains main new features, such as extended voltage-dependent current limit tables (VDLp, VLDq curves), local current compensation, local reactive-droop compensation, reactive-current injection algorithm, model inverter blocking logic etc. REEC_A or REEC_B (older versions) can be converted to REEC_D with modifying some parameters [5].

REPC controller represents the park controller model. It monitors the point of interconnection (POI) of a plant and sends real and reactive power commands to PV inverters in the plant to control the

real power and reactive power/voltage/power factor at the POI. In EMTP, REPC_A model is implemented which is the original simple plant level controller [2].

The mechanical system includes wind turbine generator aerodynamics model (WTGA), wind turbine generator shaft model (WTGT), wind turbine generator pitch controller model (WTGP), and wind turbine generator torque controller model (WTGQ).

The park model includes the collector system of the plant, converter transformer, and park transformer. The converter model including the converter transformer and the collector system are aggregated. The converter and the control systems include the necessary nonlinearities, transient and protection functions to simulate accurately the transient and dynamic behavior of the converter to external power system disturbances.

The control system models can run from a compiled code. The simulation speed increases when the model run from the compiled code.

The model is an open source and a flexible model. User can easily modify the control block diagrams and adapt the control parameters according to the specified design used in the wind park plant. The model is valid for load-flow, time-domain and frequency scan simulation types.

2 wind park Pins and Device Mask

The section describes the converter pins and device mask.

2.1 wind park pins

This device has 2 pins:

Table 1 Wind Park model Pins

Pin name	Port type	Description	Units
PCC	3-phase power	Point of Common Coupling	

2.2 Parameters

2.2.1 General tab

- **Number of aggregated inverters:** number of parallel-connected wind turbines.
- **Frequency:** grid frequency.
- **Collector grid nominal AC voltage:** voltage on the collector grid.
- **Transmission grid nominal AC voltage:** voltage on the transmission grid.
- **Including zig-zag transformer on the collector grid:** if this option is checked, a zig-zag transformer is added on LV side of the park transformer.
- R_0 : primary winding resistance of the zig-zag transformer
- L_0 : primary winding inductance of the zig-zag transformer
- **Wind turbine rated power:** rated apparent power of a single wind turbine/inverter.
- **Inverter nominal voltage:** nominal voltage of inverter.
- **DC voltage:** DC-link voltage.
- **Filter reactive power:** reactive power generated by each inverter harmonic filter. See 3.2 for more information on the filter.
- **Choke resistance:** choke resistance.
- **Choke inductance:** choke inductance.
- **Include equivalent collector grid:** if this option is checked, an equivalent PI model collector grid is added between inverter transformer and park transformer.
- **Equivalent resistance:** collector grid equivalent resistance.
- **Equivalent inductance:** collector grid equivalent inductance.
- **Equivalent capacitance:** collector grid equivalent capacitance.
- **Number of inverters in service:** number of parallel-connected arrays/inverters in service.
- **Q-control mode:** Q-control, V-control or PF-control.
- Note: this parameter regulates reactive power or voltage, or power factor at POI.
- **Reactive power reference:** reactive power reference at point of interconnection.
- **Voltage reference:** voltage reference at point of interconnection.
- **Power factor reference:** power factor reference at point of interconnection.
- **Active power reference:** active power reference at point of interconnection.

2.2.2 Park Transformer tab

The 'Nominal three-phase nameplate input' transformer model from the standard EMTP library is used.

- **Connection Type:** see options.
- **Nominal power:** nominal power of a single transformer.
- **Nominal frequency:** nominal frequency of the transformer.
- **Grid side voltage:** nominal voltage transformer on the grid side.
- **Inverter side voltage:** nominal voltage transformer on the inverter side.
- **Winding R:** winding resistance.
- **Winding X:** winding reactance.
- **Winding impedance on winding 1:** distribution ratio

- **Magnetization data:** current-flux data.
- **Magnetization resistance:** magnetization resistance.
- **Exclude magnetization branch model:** if this option is checked, the magnetization branch model is excluded.

2.2.3 Inverter Transformer tab

The 'Nominal three-phase nameplate input' transformer model from the standard EMTP library is used.

In the converter transformer tab, the data must insert for the one converter transformer. The converter model is aggregated. Therefore, the converter transformer is aggregated according to number of aggregated converters, which is automatically done by a script. The total nominal power of one aggregated converter transformer is equal to one converter transformer nominal power multiplied by the number of aggregated converters.

- **Connection Type:** see options.
- **Nominal power:** nominal power of a single transformer.
- **Nominal frequency:** nominal frequency of the transformer.
- **Grid side voltage:** nominal voltage transformer on the grid side.
- **Inverter side voltage:** nominal voltage transformer on the inverter side.
- **Winding R:** winding resistance.
- **Winding X:** winding reactance.
- **Winding impedance on winding 1:** distribution ratio.
- **Magnetization data:** current-flux data.
- **Magnetization resistance:** magnetization resistance.
- **Exclude magnetization branch model:** If this option is checked, the magnetization branch model is excluded.

2.2.4 Mechanical system tab

- Wind turbine type: it can be either type 3 or type 4. If type 4 is selected, the user needs to set WTGT model parameters only.

2.2.4.1 WTG torque controller model-WTQQ_A

- **Torque control:** it can be either for speed error or for power error.
- **Proportional gain in torque regulator K_{pp} :** proportional gain in torque regulator.
- **Proportional gain in torque regulator K_{ip} :** integral gain in torque regulator.
- **Electrical power system time constant T_p :** electrical power system time constant.
- **Speed reference time constant T_{wref} :** speed reference time constant.
- **Maximum limit in torque regulator $Temax$:** maximum limit in torque regulator.
- **Minimum limit in torque regulator $Temin$:** minimum limit in torque regulator.
- **Power P1:** speed-power curve of turbine, power P1.
- **Shaft speed for power P1:** speed-power curve of turbine, shaft speed for power P1.
- **Power P2:** speed-power curve of turbine, power P2.
- **Shaft speed for power P2:** speed-power curve of turbine, shaft speed for power P2.
- **Power P3:** speed-power curve of turbine, power P3.
- **Shaft speed for power P3:** speed-power curve of turbine, shaft speed for power P3.
- **Power P4:** speed-power curve of turbine, power P4.
- **Shaft speed for power P4:** speed-power curve of turbine, shaft speed for power P4.

2.2.4.2 WTG pitch controller model – WTGP_B

- **Pitch control integral gain K_{iw} :** pitch control integral gain.
- **Pitch control proportional gain K_{pw} :** pitch control proportional gain.
- **Pitch compensation integral gain K_{ic} :** pitch compensation integral gain.
- **Pitch compensation proportional gain K_{pc} :** pitch compensation proportional gain.
- **Gain K_{cc} :** power speed gain.

- **Blade response time constant T_{theta}** : blade response time constant.
- **Maximum pitch angle $Theta_{Max}$** : maximum pitch angle.
- **Minimum pitch angle $Theta_{Min}$** : minimum pitch angle.
- **Maximum pitch angle rate $dTheta_{Max}$** : maximum pitch angle rate.
- **Minimum pitch angle rate $dTheta_{Min}$** : minimum pitch angle rate.
- **Maximum compensation controller $Thetac_{Max}$** : maximum compensation controller.
- **Minimum compensation controller $Thetac_{Min}$** : minimum compensation controller.
- **Maximum speed error controller $Thetaw_{Max}$** : maximum speed error controller.
- **Minimum speed error controller $Thetaw_{Min}$** : minimum speed error controller.

2.2.4.3 WTG shaft model- WTGT_B

- **Pm selector**: it can be either from Pm or Pe.
- **Time constant of Pm T_p** : time constant of Pm.
- **Turbine inertia H_t** : turbine inertia.
- **Generator inertia H_g** : generator inertia.
- **Shaft damping factor D_{shaft}** : shaft damping factor.
- **Spring constant K_{shaft}** : spring constant.
- **Machine damping factor **Damp****: machine damping factor.
- **Initial rotor speed W_0** : initial rotor speed. When Torque control of the WTGQ model is in the speed error control, this parameter is automatically set according to the speed-power curve of the WTGQ model.

2.2.4.4 WTG aerodynamic model – WTGA_A

- **Initial $Theta_0$** : initial pitch angle.
- **Aero gain factor K_a** : aerodynamic gain factor.

2.2.5 Converter control tab

- **Converter model**: It can be either DM, detailed model + generic current control model, AVM, average value model + generic current control model, current source + REGC_A model, or voltage source + REGC_C model.
- **Use compiled code for the data acquisition**: using compiled code will increase the simulation speed.
- **Use compiled code for the inverter control system**: using compiled code will increase the simulation speed.

2.2.5.1 AVM or DM converter models

- **PWM frequency**: PWM frequency
- **PLL K_i** : PLL PI controller, integral gain.
- **PLL K_p** : PLL PI controller, proportional gain.
- **Current loop PI controller parameters**: PI controller gains or rise time.
- **PI controller K_i** : PLL PI controller, integral gain
- **PI controller K_p** : PLL PI controller, proportional gain.
- **Rise time**: closed-loop current control rise-time.
- **R_{sys}** : equivalent resistance of the external network.
- **X_{sys}** : equivalent reactance of the external network.
- **Sampling rate**: sampling rate frequency.
- **Measuring input filter type**: Bessel or Butterworth.
- **Measuring input filter order**
- **Cutoff frequency**: cutoff frequency of measuring input filters.

- **Rate flag switch:** ramp rate limit on active current or active power.
- **Voltage filter time constant T_{filtr} :** filter time constant for voltage measurement.
- **Upper ramp rate limit I_{qrmax} :** maximum rate at which a reactive current recover after a fault.
- **Lower ramp rate limit I_{qrmin} :** minimum rate at which a reactive current recover after a fault.
- **Ramp rate limit for active power $rrpwr$:** rate a which active current (power) recovers after a fault.

2.2.5.2 REGC_A converter model

- **Low Voltage Power Logic:** low voltage power limiter (LVPL) logic is enabled when flag Lvplsw is set 1.
 - **Converter time constant T_g :** converter current regulator lag time constant.
 - **Active current ramp rate limit Rrpwr:** active current up-ramp rate limit on voltage recovery.
 - **LVPL characteristic voltage 2 Brkpt:** LVPL breakpoint voltage.
 - **LVPL characteristic voltage 1 Zerox:** LVPL zero crossing voltage.
 - **LVLP gain Lvpl1:** LVPL gain.
 - **Voltage limit Volim:** voltage limit in high voltage reactive current.
 - **High voltage point Lvptnt1:** high voltage point for low voltage active current management.
 - **Low voltage point Lvptnt0:** low voltage point for low voltage active current management.
 - **Current limit lolim:** limit in high voltage reactive current management.
 - **Voltage filter time constant Tfiltr:** terminal voltage filter time constant for low voltage active current management.
 - **Overvoltage compensation on gain Khv:** overvoltage compensation or gain Acceleration factor (Accel) used in the high voltage reactive current management.
 - **Upper limit Iqrmax:** upper limit on rate of change for reactive current.
 - **Lower limit Iqrmin:** lower limit on rate of change for reactive current.
- Voltage angle measurement
- **Proportional-gain Kppll:** PLL PI controller, proportional gain
 - **Integral gain Kipll:** PLL PI controller, integral gain
 - **Upper limit wmax:** PLL PI controller, upper limit.
 - **Lower limit wmin:** PLL PI controller, lower limit.

2.2.5.3 REGC_C converter models

- **Rate flag switch:** ramp rate limit on active current or active power.
- **Upper ramp rate limit I_{qrmax} :** maximum rate at which a reactive current recover after a fault.
- **Lower ramp rate limit I_{qrmin} :** minimum rate at which a reactive current recover after a fault.
- **Voltage filter time constant T_{filtr} :** filter time constant for voltage measurement.
- **Ramp rate limit for active power $rrpwr$:** rate a which active current (power) recovers after a fault.
- **Time constant T_e :** filter time constant to model inner control loops.
- **Proportional-gain Kip:** inner current loop PI controller, proportional gain
- **Integral gain Kii:** inner current loop PI controller, integral gain
- **Proportional-gain Kppll:** PLL PI controller, proportional gain
- **Integral gain Kipll:** PLL PI controller, integral gain
- **Upper limit wmax:** PLL PI controller, upper limit.
- **Lower limit wmin:** PLL PI controller, lower limit.

2.2.5.4 REEC_D control model

- **Power factor control PFlag:** power factor control or Q control (which can be controlled by an external signal)
- **Voltage/Q control VFlag:** Q control or voltage control
- **Voltage/Q/PF control QFlag:** voltage or Q control, or constant pf or Q control
- **P dependency PFlag:** active current command has speed dependency or no dependency (always set to 0 for solar PV plant)
- **P/Q priority Pqflag:** reactive power priority or active power priority
- **Q compensation Vcmpflag:** use current compensation or use reactive droop
- **Baseload flag:** Normal operation, or P_{MAX}= initial power (P_{gen0}), or P_{MAX}=P_{MIN}=Initial power (P_{gen0}).
- **Low voltage threshold Vdip:** low voltage condition trigger voltage.
- **High voltage threshold Vup:** high voltage condition trigger voltage.
- **Time constant Trv:** terminal bus voltage filter time constant.
- **Gain Kqv:** Reactive current injection gain during over and undervoltage conditions.
- **Overvoltage deadband dbd1:** overvoltage deadband for reactive current injection (≤ 0).
- **Undervoltage deadband dbd2:** undervoltage deadband for reactive current injection (≥ 0).
- **Upper limit Iqh1:** maximum reactive current injection.
- **Lower limit Iql1:** minimum reactive current injection.
- **Voltage reference Vref0:** reference voltage for reactive current injection (if 0, model initializes it to initial terminal voltage automatically).
- **Constant Iqfrz:** value at which I_{qinj} is held for thld seconds following a voltage dip event.
- **Time delay Thld:** time delay associated with I_{qinj} when voltage_dip is reset from 1 to 0:
 - a) If Thld = 0, no other action is taken.
 - b) If Thld > 0, then for Thld seconds following a voltage dip (i.e. voltage_dip goes from 1 back to 0) I_{qcmd_bl} is held at its current value (i.e. value just prior to the end of the voltage_dip) for Thld seconds and is then released.
 - c) If Thld < 0, then for Thld seconds following a voltage dip (i.e. voltage_dip goes from 1 back to 0) I_{qcmd_bl} is held equal to I_{qfrz} for Thld seconds and is then released.
- **Time delay Thld2:** time delay that active current command is held/frozen at the previous value for Thld2 seconds following a voltage dip, i.e. voltage_dip goes from 1 back to 0
- **Upper limit Qvmax:** maximum value of the incoming Q_{ext} or V_{ext} (≥ 0).
- **Lower limit Qvmin:** minimum value of the incoming Q_{ext} or V_{ext} (≤ 0).
- **Upper limit VMAX:** maximum voltage at inverter terminal bus (≥ 0).
- **Lower limit VMIN:** minimum voltage at inverter terminal bus (≤ 0).
- **Proportional gain Kqp:** local reactive power regulator proportional gain.
- **Integral gain Kqi:** local reactive regulator integral gain.
- **Proportional gain Kvp:** local voltage regulator proportional gain.
- **Integral gain Kvi:** local voltage regulator integral gain.
- **Voltage reference Vref1:** inner-loop voltage control reference. Note: this parameter is a user defined parameter which is added to “refs” input bundle.
- **Time constant Tiq:** reactive current regulator lag time constant.
- **Up_ramp limit dPmax:** active power up-ramp limit (>0).
- **Down_ramp limit dPmin:** active power down-ramp limit (>0).
- **Upper limit PMAX:** maximum active power.
- **Lower limit PMIN:** minimum active power.
- **Time constant Tp:** active power filter time constant.
- **Time constant Tpod:** inverter power order lag time constant.
- **Compensation resistance rc:** current-compensation resistance.
- **Compensation reactance Xc:** current-compensation reactance.
- **Time constant Tr1:** filter time constant for voltage measurement. It can be set to “zero”.
- **Compensation gain Kc:** reactive-current compensation gain.
- **Low voltage threshold Vblk:** voltage below which the converter is blocked (i.e. I_q = I_p = 0).

- **High voltage threshold Vblkh:** voltage above which the converter is blocked (i.e. $I_q = I_p = 0$).
- **Time delay Tblk:** the time delay following blocking of the converter after which the converter is released from being blocked.
- **Scaling gain Ke:** Scaling on I_{pmin} ; set to 0 for a generator, set to a value between 0 and 1 for a storage device, as appropriate.
- **Maximum current Imax:** maximum apparent current.
- **VDLq data:** 12 pairs of values defining the voltage dependent reactive-current limits. Voltage versus reactive-current curve for VDLq data.
- **VDLp data:** 12 pairs of values defining the voltage dependent active-current limits. Voltage versus active-current curve for VDLp data.

2.2.6 Protection tab

2.2.6.1 Voltage sag protection

- **Enable:** if this option is checked, the voltage sag protection is enabled.
- **Pickup DVS voltage:** threshold voltage value to activate the Deep-Voltage-Sag (DVS) protection.
- **Reset DVS voltage:** threshold voltage value to deactivate the Deep-Voltage-Sag protection.

2.2.6.2 Chopper protection

- **Enable:** if this option is checked, the chopper protection is enabled.
- **Pickup V_{DC} :** chopper is ON when dc-voltage is above this value.
- **Reset V_{DC} :** chopper OFF when dc-voltage is below this value.

2.2.6.3 Overcurrent protection

- **Inverter pickup current:** converter overcurrent protection threshold.
- **Reset delay:** overcurrent protection release delay.

2.2.6.4 AC undervoltage protections

- **Enable:** if this option is checked, the AC undervoltage protection is enabled.
- **AC undervoltage protection data:** voltage versus time curve for the AC undervoltage protection.

2.2.6.5 AC overvoltage protections

- **Enable:** if this option is checked, the AC overvoltage protection is enabled.
- **AC overvoltage protection data:** voltage versus time curve for the AC overvoltage protection.

2.2.7 Park controller tab

2.2.7.1 Q/V control

- **Voltage droop control VCFalg:** reactive droop or line drop compensation.
- **Time constant Tfltr:** voltage and reactive power filter time constant.
- **Proportional gain Kp:** Volt/VAr regulator proportional gain.
- **Integral gain Ki:** Volt/VAr regulator integral gain.
- **Lead time constant Tft:** plant controller Q output lead time constant.
- **Lag time constant Tfv:** plant controller Q output lag time constant.
- **Voltage Vfrz:** voltage for freezing Volt/VAr regulator integrator.
- **Compensation resistance Rc:** line drop compensation resistance.
- **Compensation reactance Xc:** line drop compensation reactance.

- **Compensation gain Kc:** reactive droop gain.
- **Upper limit emax:** maximum Volt/VAr error.
- **Lower limit emin:** minimum Volt/VAr error.
- **Lower threshold for deadband dbd1:** reactive power lower threshold deadband.
- **Upper threshold for deadband dbd2:** reactive power upper threshold deadband.
- **Upper limit Qmax:** maximum plant reactive power command.
- **Lower limit Qmin:** minimum plant reactive power command.

2.2.7.2 P/frequency control

- **Frequency control Fflag:** governor response disable or enable.
- **Proportional gain Kpg:** real power control proportional gain.
- **Integral gain Kig:** real power control integral gain.
- **Time constant Tp:** active power filter time constant.
- **Lower threshold deadband fdbd1:** frequency deadband downside.
- **Upper threshold deadband fdbd2:** frequency deadband upside.
- **Upper limit femax:** maximum power error in droop regulator.
- **Lower limit femin:** minimum power error in droop regulator.
- **Upper limit Pmax:** maximum plant active power command.
- **Lower limit Pmin:** minimum plant active power command.
- **Time constant Tg:** plant controller P output lag time constant.
- **Over-frequency droop Ddn:** reciprocal of down regulation droop.
- **Under-frequency droop Dup:** reciprocal of up regulation droop.

2.2.8 Harmonics tab

- **Use harmonic model for steady-state and time-domain simulations:** if this option is checked, this device is modeled as a harmonic current source for steady-state and time-domain simulations.
- **Use harmonic model for frequency-scan simulations:** if this option is checked, the Fundamental frequency current magnitude input and the first line of the Harmonic data table are adjusted to match the load-flow solution current.
- **Adjust fundamental frequency current to match load-flow solution results:** if this option is checked, this device is modeled as a harmonic current source during Frequency scan simulations.
- **Fundamental frequency current magnitude (for one inverter):** magnitude of the fundamental frequency current for 1 inverter in A RMS. This value is automatically multiplied by the number of inverters in service.
- **Harmonics data table:** harmonic contents for phase-a (balanced source).

3 WECC Wind Park model

3.1 General

The general structure of the wind park model is shown in Figure 1. It is composed of

- “Hardware” block which contains the converter model,
- “Converter Control” block,
- “Power Plant Controller (PPC)” block,
- PI circuit that represents equivalent collector grid,
- converter transformer (converter_transformer),
- park transformer,
- initialization sources with load flow (LF) constraint, and
- a Norton harmonic source for harmonic analysis.

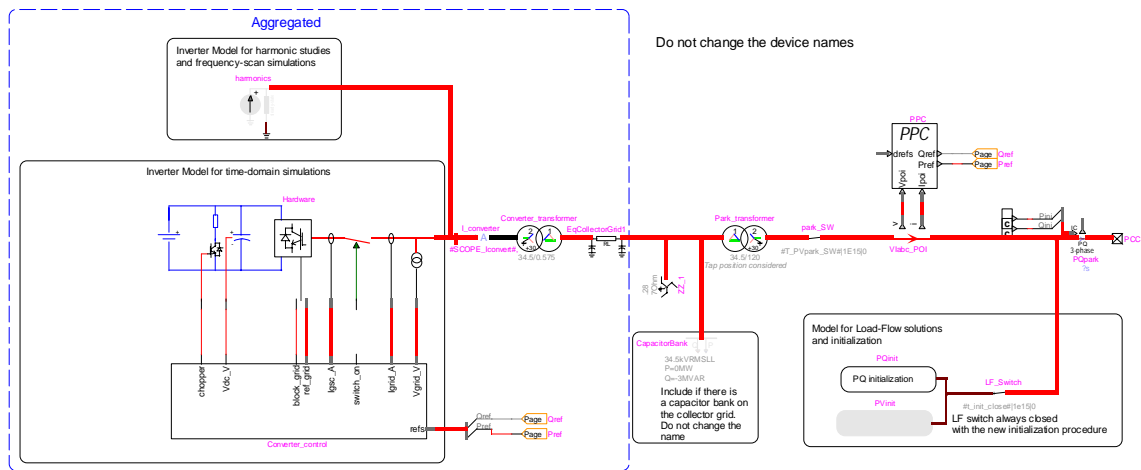

Figure 1 General structure of WECC WP park model.

The Wind Park content is automatically modified according to the simulation type, so the model is valid for any simulation options EMTF offers.

During load-flow, the converter is modelled by a PQ load-flow bus. The load-flow power is the *Initial active power* input, the reactive power is the *Initial reactive power input*.

In time-domain, the model is initialized with the load-flow conditions and the outer loop control initial references are the ones used during load-flow, which were detailed in the section hereabove. The initialization time is $t_{init} = 0.05s$. During this time, an ideal voltage source is connected to the converter 3-phase pin. This voltage source holds the load-flow conditions while the converter controls are initializing. After this time, the ideal voltage source is disconnected by a switch.

During frequency-scan analysis, the converter hardware and converter control system is replaced a Norton harmonic source. It is connected to the low-voltage side of the converter transformer if the latter is included. No control is included when the harmonic representation is selected.

The Wind Park model is an aggregated model, and it is aggregated according to the number of wind turbines (see Figure 1 aggregated zone).

3.2 Hardware

For Type 3 and Type 4 WECC generic dynamic models, the generator combination is represented by a very simple model neglecting all machine flux dynamics [6].

The inverter/generator/converter model can be

- detailed model (DM),
- average value model (AVM),
- current source, or
- voltage source.

DM and AVM can be used for the Type 4 WTG, representing the grid-side inverter. The inverter is model as current controlled voltage source inverter, which the output current of the inverter is regulated by controlling of the voltage of the inverter. The DC bus voltage is simply connected to a constant DC voltage. For more information, see the WECC PV model documentation.

3.3 Mechanical control system

The mechanical system includes following [7].

1. WTGT_B- which is the emulation of the drive-train oscillations (see Figure 2). This model is used for type 3 and type 4 WTG plants. For type 4, the only input is the electrical power (P_e) of the generator and mechanical power (P_m) is simply taken to be a filtered value of P_e .
2. WTGP_B – which is the pitch-control model (see Figure 3). This model is used for type 3 WTG plants.
3. WTGA_A – which is the linear model of the turbine aero-dynamics (see Figure 4). This model is used for type 3 WTG plants.
4. WTGQ_A – which is the torque controller (see Figure 5). This model is used for type 3 WTG plants.

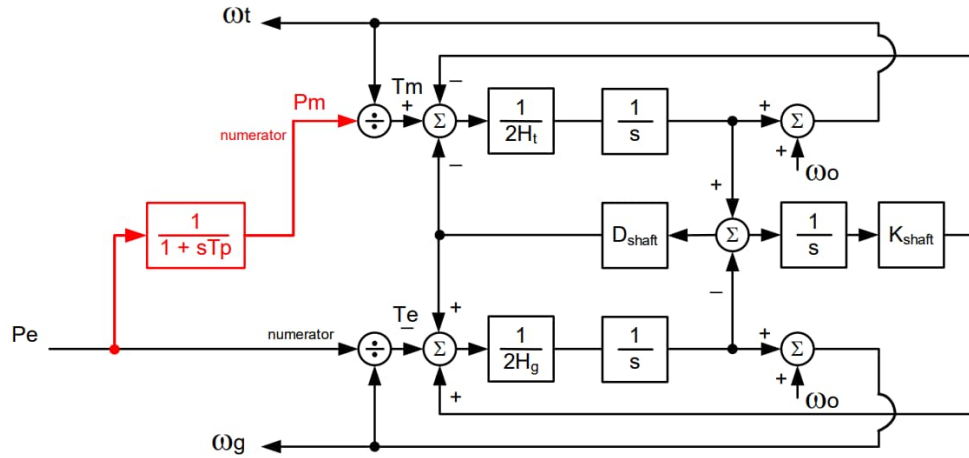

Figure 2 WTGT_B model [1].

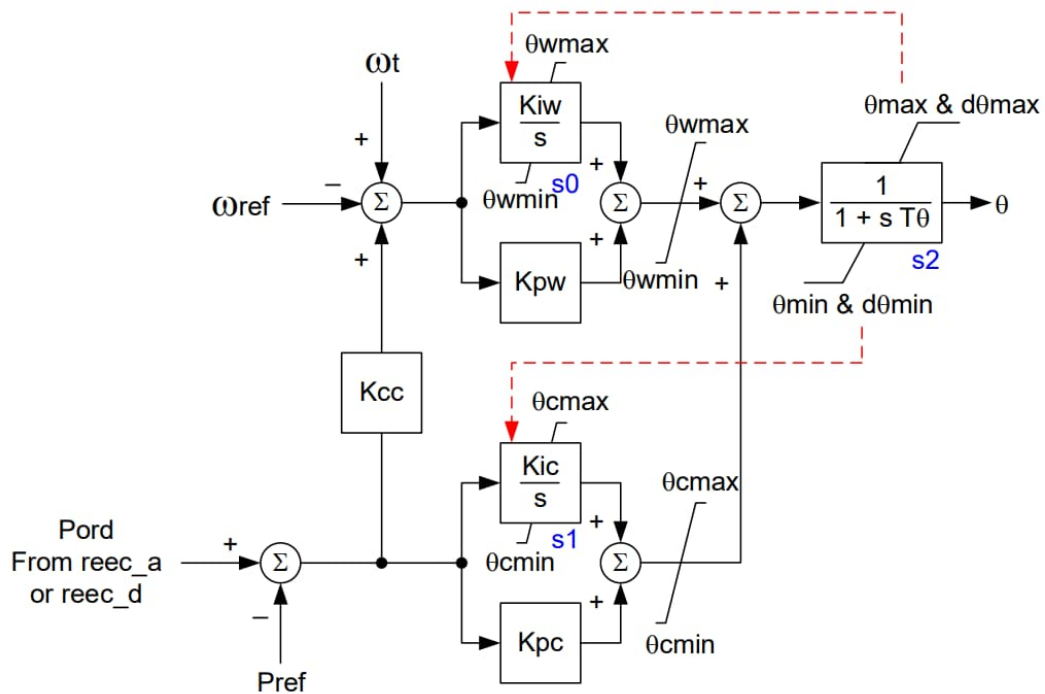

Figure 3 WTGP_B model [1].

o

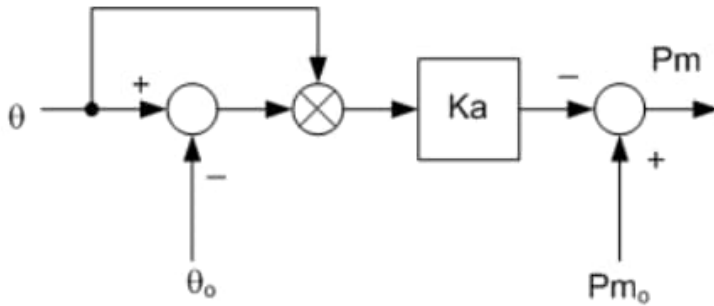

Figure 4 WTGA_A model [7].

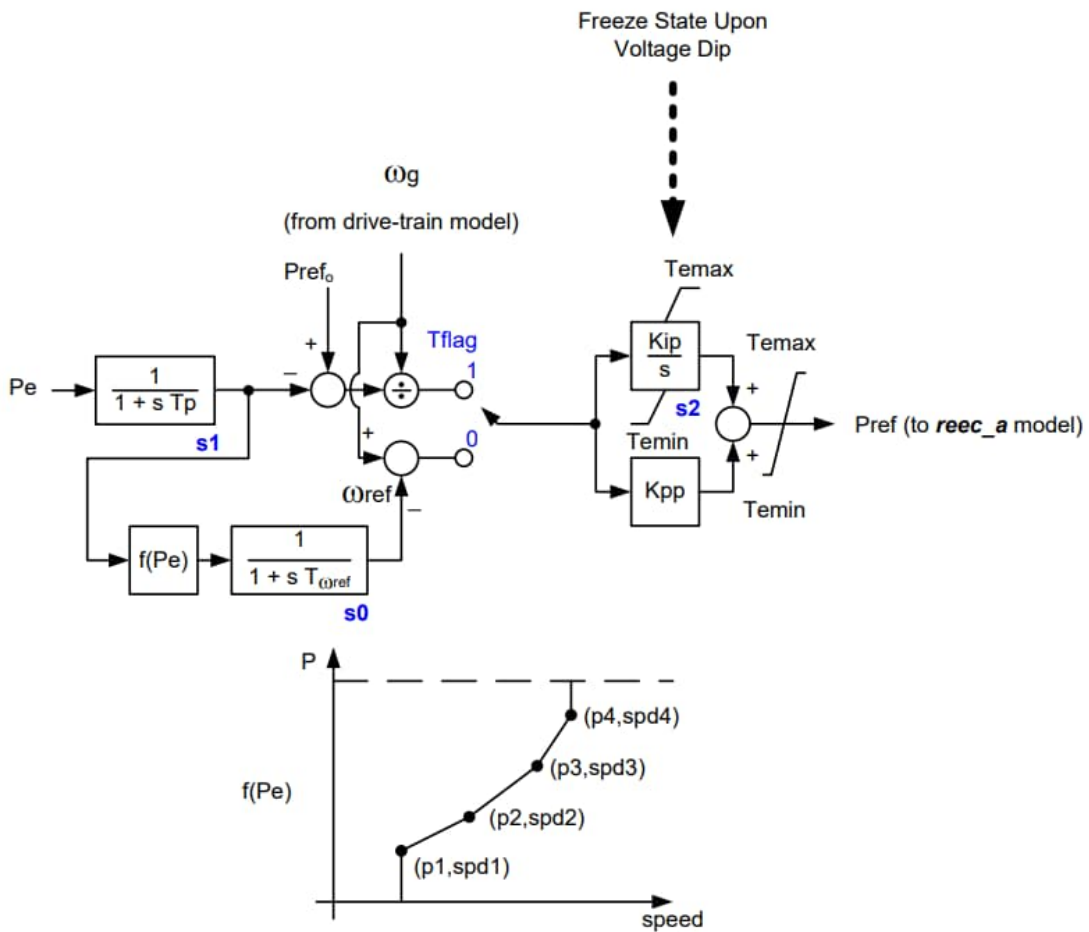

Figure 5 WTGP_A model [7].

3.4 Converter control system

The EMTD diagram of the inverter control system block (or “Converter_control” block) is shown in Figure 6. The sampled signals are converted to pu and filtered by the data acquisition block. The

sampling frequency are set to 12.5 kHz and can be modified by the user from the device mask. The “sampling” blocks are deactivated in AVM, REGC_A and REGC_C, due to large simulation time step usage. In generic model, 2nd order Bessel type low pass filters (LPFs) are used. The cut-off frequencies of the filters are set to 2.5 kHz and can be modified by the user from the inverter device mask. The order (up to 8th order), the type (Bessel and Butterworth) and the cut-off frequencies of the low pass filters can be modified from device mask. The “LPF_GCS” blocks are deactivated in REGC_A and REGC_C. The protection block includes the AC over/under voltage protections, deep voltage sag detector, the DC chopper control, and overcurrent detector. The control system offers REEC_D for the outer loop control, and a generic decoupled control, WECC REGC_A model, or WECC REGC_C model options for the inner current control loop. User can select the control system options from the device mask (see Section 2.2). The data acquisition and control system models can run from a compiled code. Faster simulation time is obtained compared with the EMTP component-based model by using this option.

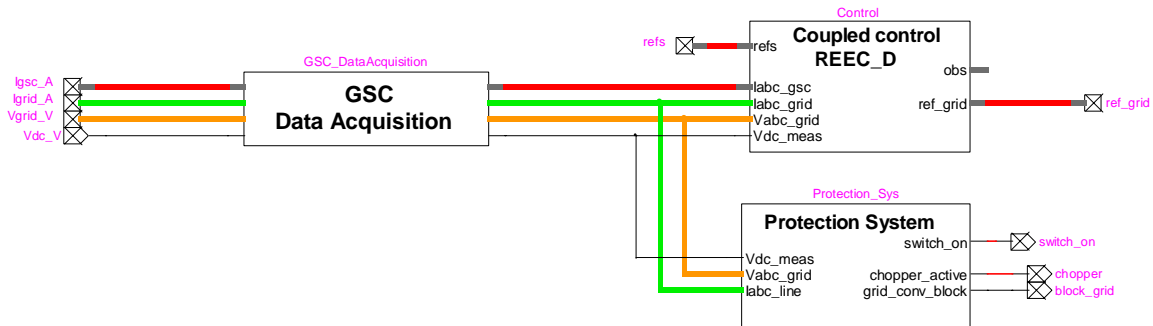

Figure 6 EMTP diagram of the PV inverter control block.

3.4.1 Computing Variable block

The EMTP diagram of the “Computing variables” and “Grid Control” block is shown in Figure 7. The “GSC Computing Variables” block does the dq transformation required for the vector control. In “computing variable” block, a synchronous reference frame (SRF) PLL is used to drive the phase angle θ of the rotating reference frame from the inverter terminal voltages, allowing the synchronization of the control parameters with the system voltage [8], [9]. The EMTP diagram of the SRF PLL is shown in Figure 8. Moreover, two abc-to-dq frame transformations are used to transfer voltage and current sinusoidal waveforms to DC quantities (d and q reference frame) waveforms. The park transformation transforms abc-frame waveforms into dq-frame components rotating at synchronous speed $\omega = d\theta/dt$. In this transformation, the direct axis d is aligned with the grid voltage. If the PLL is in a steady-state condition, the q axis of the inverter voltage terminal is equal to zero [9]. The “Grid Control” block contains the outer and inner control loops.

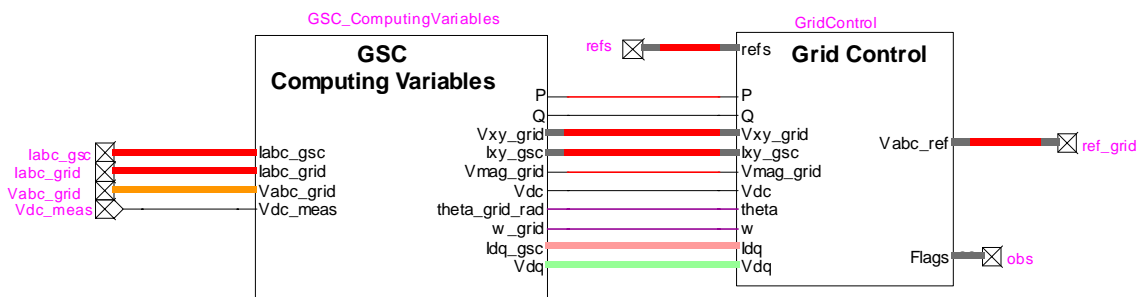

Figure 7 EMTP diagram of “Computing Variables” and “Grid Control” blocks.

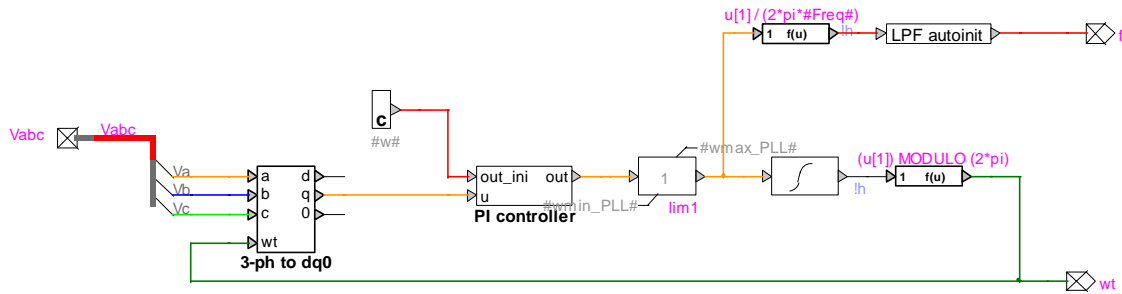

Figure 8 EMTP diagram of SRF PLL.

3.4.2 Generic current loop control

Figure 9 shows EMTP diagram of the “Grid Control” block. It is a current-controlled active and reactive controller in dq-frame. The active and reactive power of inverter are controlled by the line current components i_d (or i_p) and i_q [4], [3]. The reference current commands i_{dref} and i_{qref} for the inner current loop are generated by outer loop control “REEC_D” and “Current ramp/limit control” blocks. In the inner current control and linearization blocks, the feedback and feed-forward signals in dq-frame are processed by compensators to make the control signals. Then, they are transformed to the abc-frame and sent to the converter. The inner current loop design procedure is explained in detail in [3].

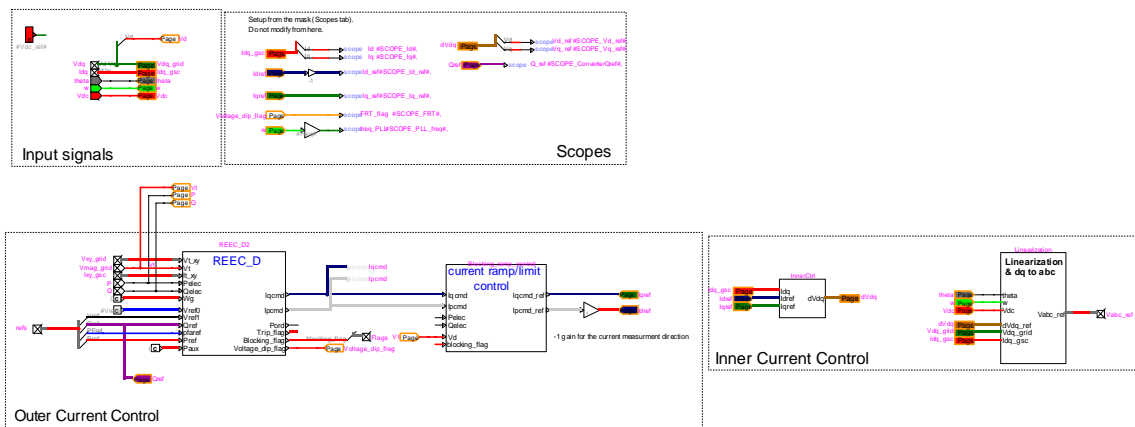

Figure 9 EMTP diagram of “Grid Control” block for REEC_D + generic current loop control model.

In “Current ramp/limit control” block, there are rate limiters to bound the command signals (I_{pcmd} and I_{pcmd}) for recovery after fault, e.g., voltage rise or drop (see Section 2.2), before sending to the inner current loop. The implementation of this rate limiters is the same as the model used for the REGC_B model.

3.4.3 REEC_D model

REEC_D block is implemented according to [1] and [5] (see Figure 10). This block generates the inverter reference currents I_{pcmd} and I_{pcmd} (see Figure 9) from active power and reactive power references sent by power plant controller. This is the most recent inverter control model developed by WECC, which contains main new features, such as extended voltage-dependent current limit tables (VDLp, VLDq curves), local current compensation, local reactive-droop compensation, reactive-current injection algorithm, model inverter blocking logic. REEC_A or REEC_B can be converted to REEC_D with modifying some parameters. [5].

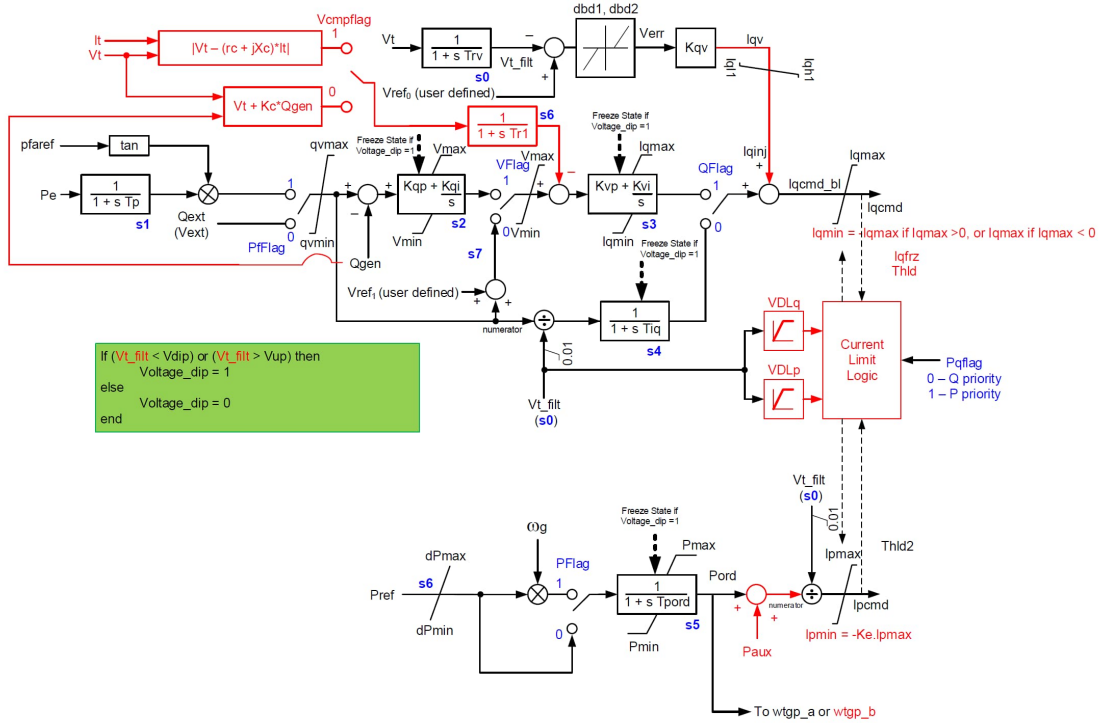

Figure 10 REEC_D model [1].

3.4.4 Generic current loop control

Figure 9 shows EMTF diagram of the “Grid Control” block. It is a current-controlled active and reactive controller in dq-frame. The active and reactive power of inverter are controlled by the line current components i_d (or i_p) and i_q [4], [3]. The reference current commands i_{dref} and i_{qref} for the inner current loop are generated by outer loop control “REEC_D” and “Current ramp/limit control” blocks. In the inner current control and linearization blocks, the feedback and feed-forward signals in dq-frame are processed by compensators to make the control signals. Then, they are transformed to the abc-frame and sent to the converter. The inner current loop design procedure is explained in detail in [3].

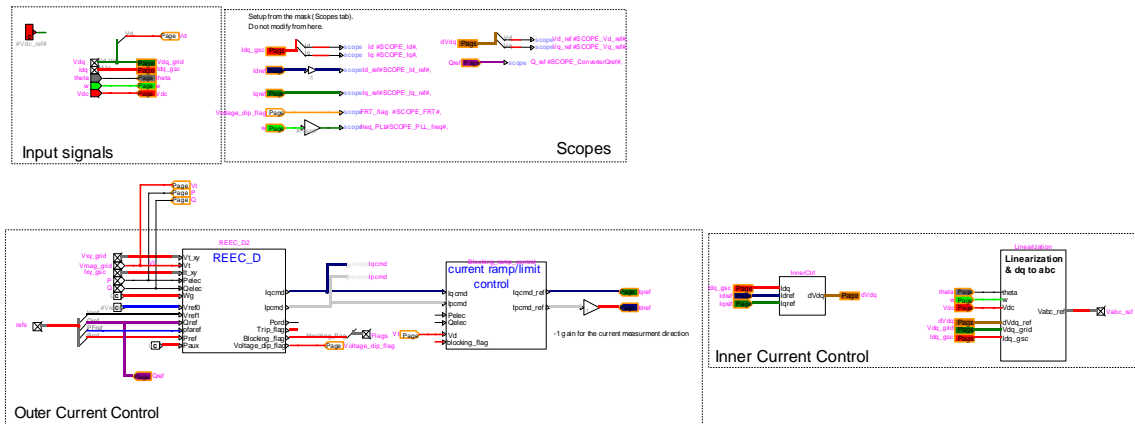

Figure 11 EMTF diagram of “Grid Control” block for REEC_D + generic current loop control model.

In “Current ramp/limit control” block, there are rate limiters to bound the command signals (I_{pcmd} and I_{qcmd}) for recovery after fault, e.g., voltage rise or drop (see Section 2.2), before sending to the inner current loop. The implementation of this rate limiters is the same as the model used for the REGC_B model.

3.4.5 REGC_A

Figure 12 shows EMTD diagram of the “Grid Control” block. Figure 13 shows the REGC_A model. As shown in Figure 13, the real active and reactive commands are passed through rate limiters and high voltage reactive current management and low voltage active current management blocks, and outputs real and reactive currents are injected to the grid by a simple current source. The active and reactive current are transferred to abc-frame at the synchronous reference frame angle calculated by a generic PLL as shown in Figure 14.

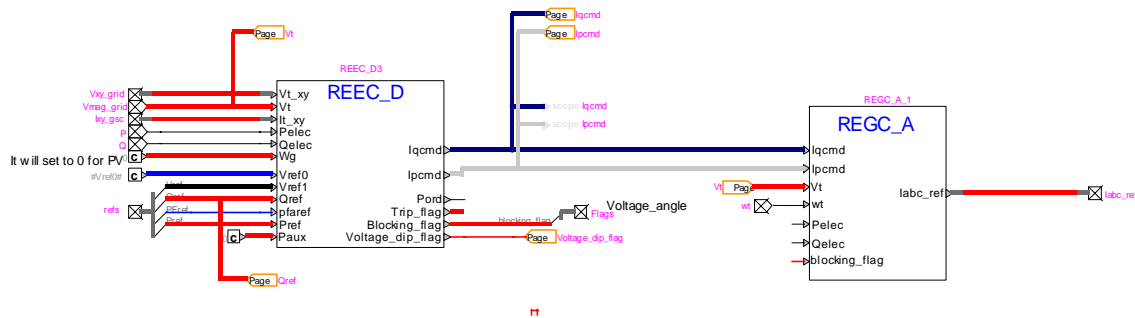

Figure 12 EMTD diagram of “Grid Control” for “REGC_A + REEC_D” model.

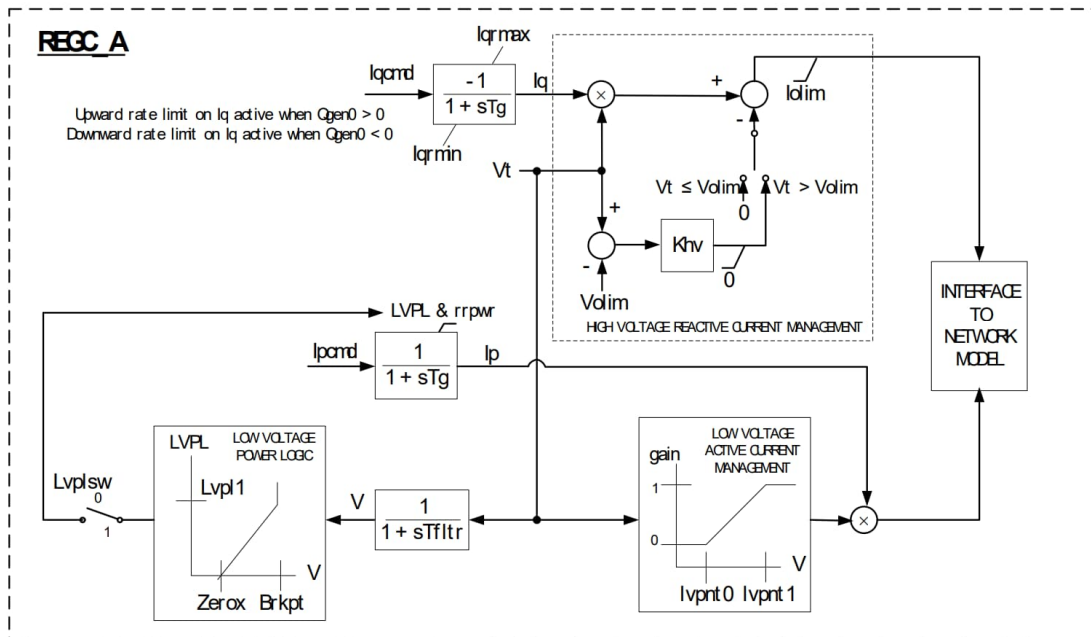

Figure 13 REGC_A model [2].

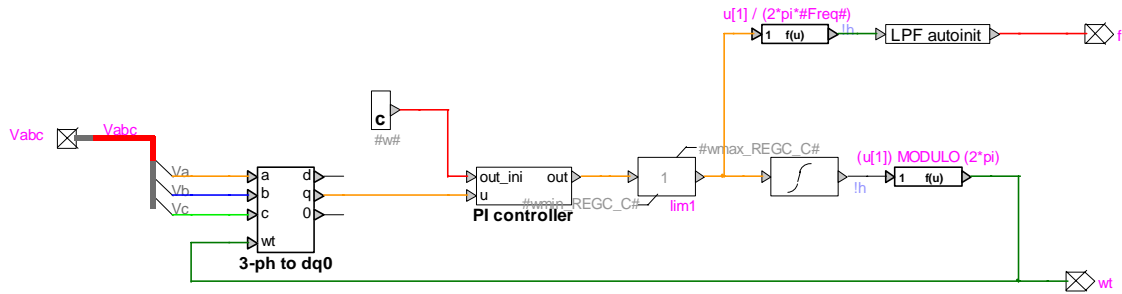

Figure 14 PLL model used in REGC_A + REEC_D model.

3.4.6 REGC_C

Figure 15 shows EMTF diagram of the “Grid Control” block. Figure 16 shows the REGC_C model. A simplified representation of the inner-current loops and an algebraic equation that compute the required voltage at the inverter terminal to inject current into the network in response to active and reactive current commands from the REEC_D model.

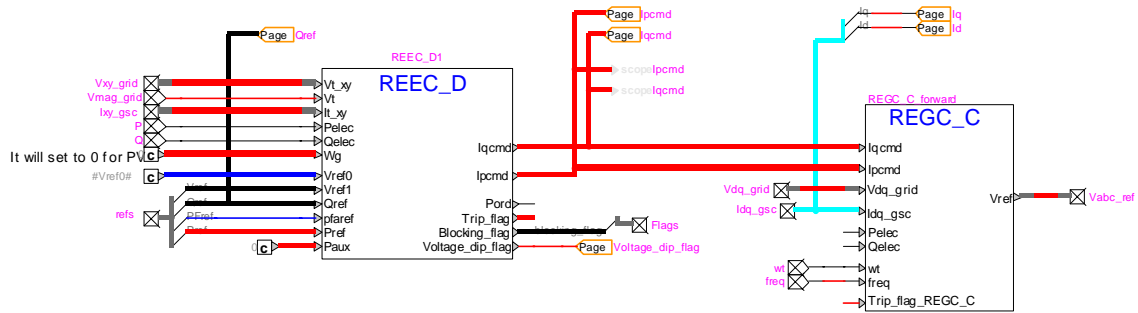

Figure 15 EMTF diagram of “Grid Control” block for the “REGC_C + REEC_D” model.

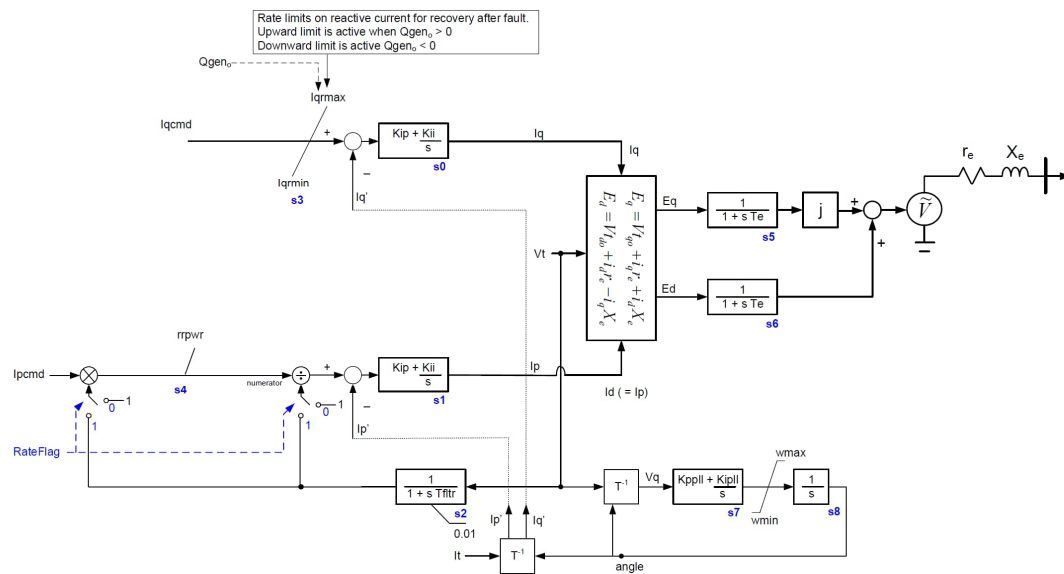

Figure 16 REGC_C model [1].

3.5 Inverter protection system block

The “protection system” block includes an over/under voltage relay, deep voltage sag detector, dc overvoltage protection and an overcurrent detector for each converter to protect IGBT devices when the system is subjected to overcurrent. For initialization, all protection systems, except for DC chopper protection, are activated after 300ms of simulation (i.e. `init_Prot_delay = 0.3s`). The protection system parameters (except over/under voltage relay) can be modified from the device mask (see Section 2.2).

3.5.1 Over/under voltage protections and deep voltage sag detector

The over/under voltage protections are designed based on the technical requirements set by Hydro Quebec for the integration of renewable generation. The over/under voltage limits as a function of time is presented in Figure 17 and can be modified in the inverter device mask. The voltages below the red line reference and above the black line reference correspond to the ride-through region where the inverter is supposed to remain connected to the grid.

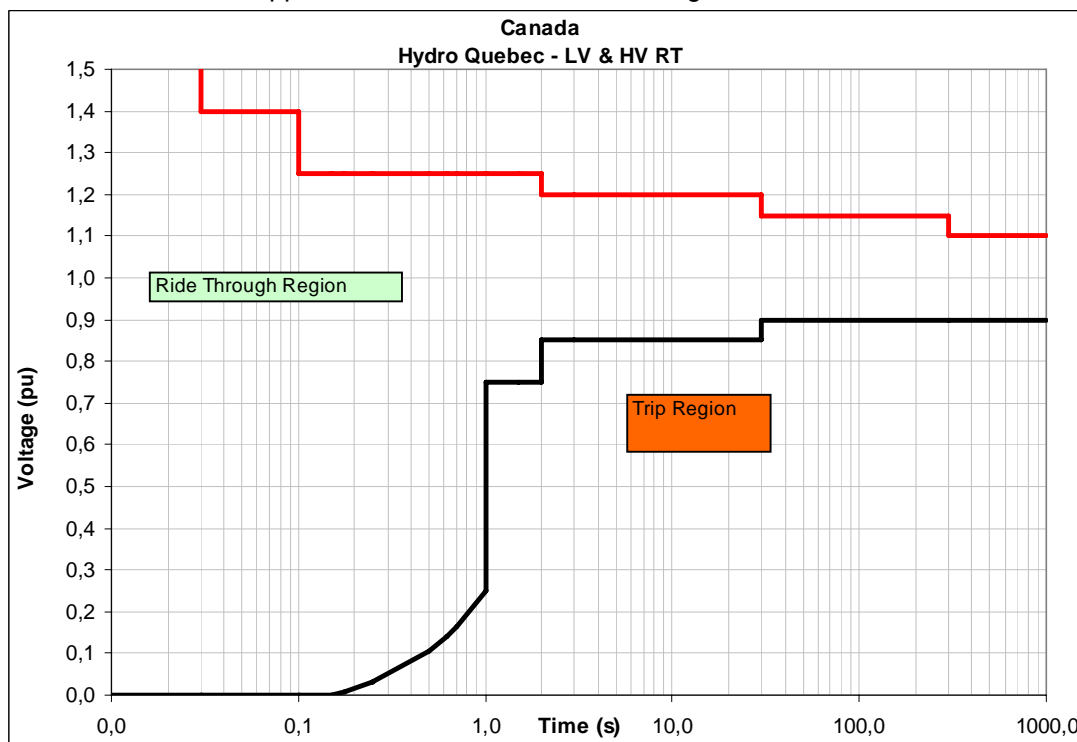

Figure 17 LVRT and HVRT requirements [10].

This block measures the rms voltages on each phase and sends a trip signal to the inverter circuit breaker when any of the phase rms voltage violates the limits in Figure 17 (see the upper part of Figure 19).

The instantaneous overvoltage protection suggested by IEEE Std 1547-2018 is developed and added to the protection schemes. This protection works based on a cumulative instantaneous overvoltage. Figure 18 shows the threshold values of the voltage (per unit of nominal instantaneous peak base) and cumulative duration of the transient overvoltage protection, and they can be modified in the device mask. The cumulative duration is the sum of durations when the instantaneous voltage exceeds the protection threshold over a one-minute time window.

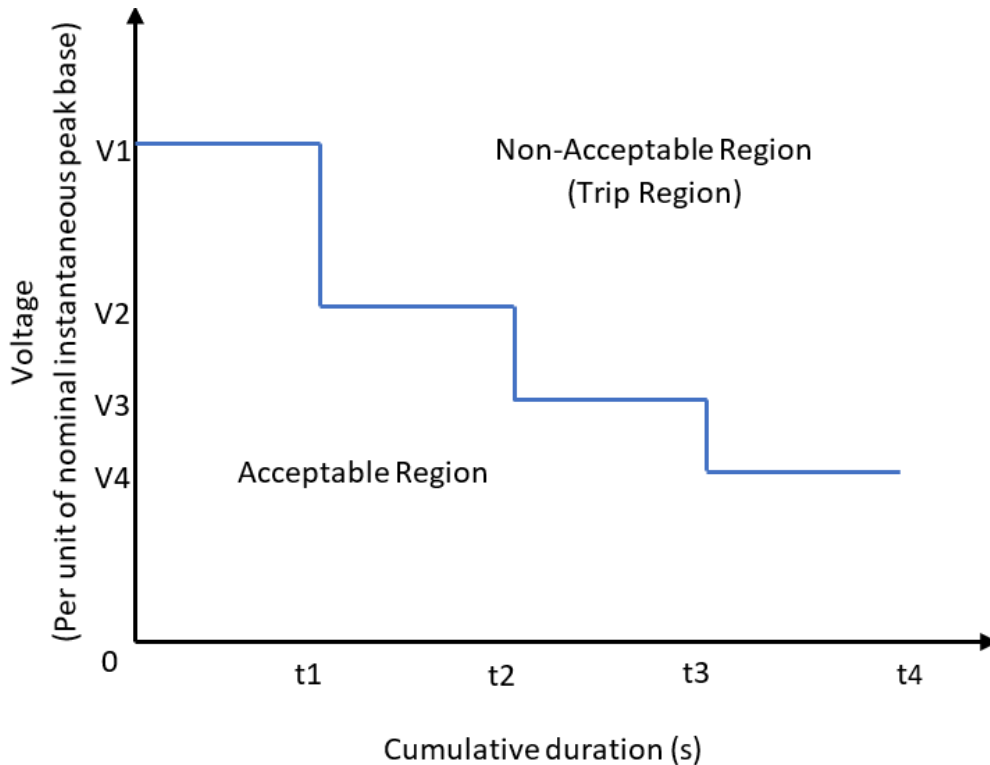

Figure 18 Transient overvoltage limits.

The “Deep Voltage Sag Detector” block (lower part of Figure 19) temporarily blocks the Inverter in order to prevent potential overcurrent and restrict the FRT operation to the faults that occur outside the inverter.

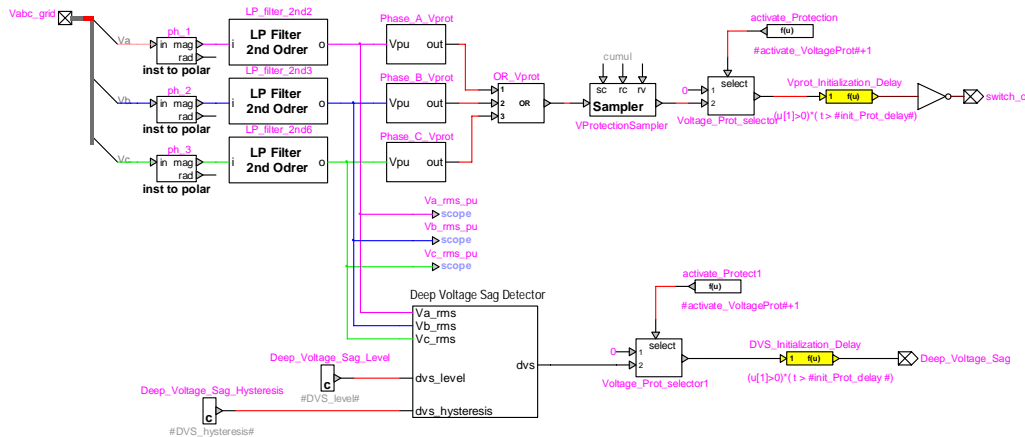

Figure 19 Over/under-voltage protections and deep voltage sag protections.

3.5.2 DC overvoltage protection block

The function of DC chopper is to limit the DC bus voltage. It is activated when the dc bus voltage exceeds $|U_{chopper-ON}|$ and deactivated when dc bus reduces below $|U_{chopper-OFF}|$. EMTP diagram of the “dc overvoltage protection” is shown in Figure 20. This protection is disabled for “REGC_A + REEC_D” and “REGC_C + REEC_D” converter models.

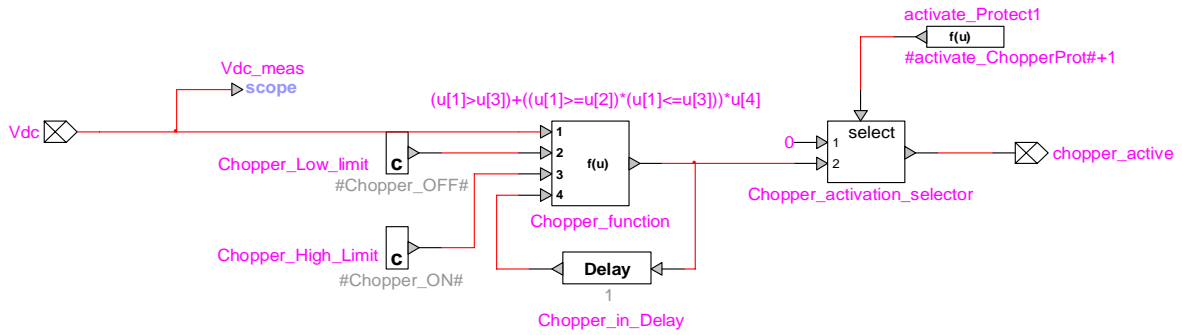

Figure 20 dc overvoltage protection block.

3.5.3 Overcurrent protection block

The overcurrent protection shown in Figure 21 blocks the converter temporarily when the converter current exceeds the pre-specified limit.

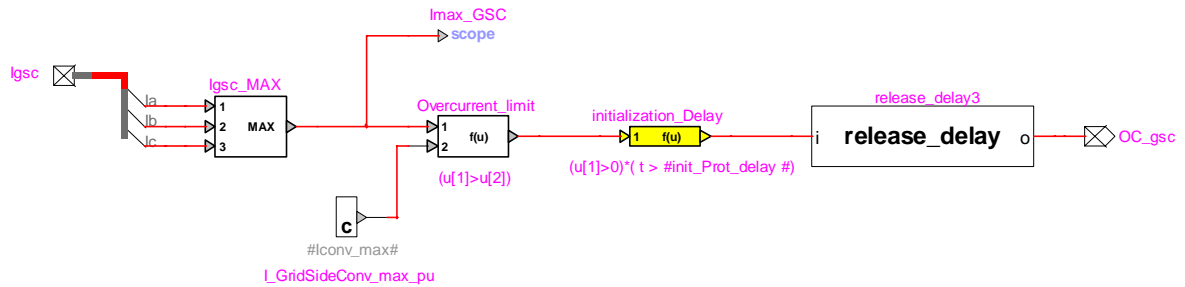

Figure 21 Overcurrent protection block.

3.6 Park controller

The function of park controller is to monitor the point of interconnection (POI) of a plant and sends real and reactive power/voltage/ power factor commands to inverters in the plant to control the real power and reactive power/voltage/power factor at the POI.

In EMTP (see PVPC block in Figure 1), REPC_A model is implemented according to model provided in [6] (see Figure 22).

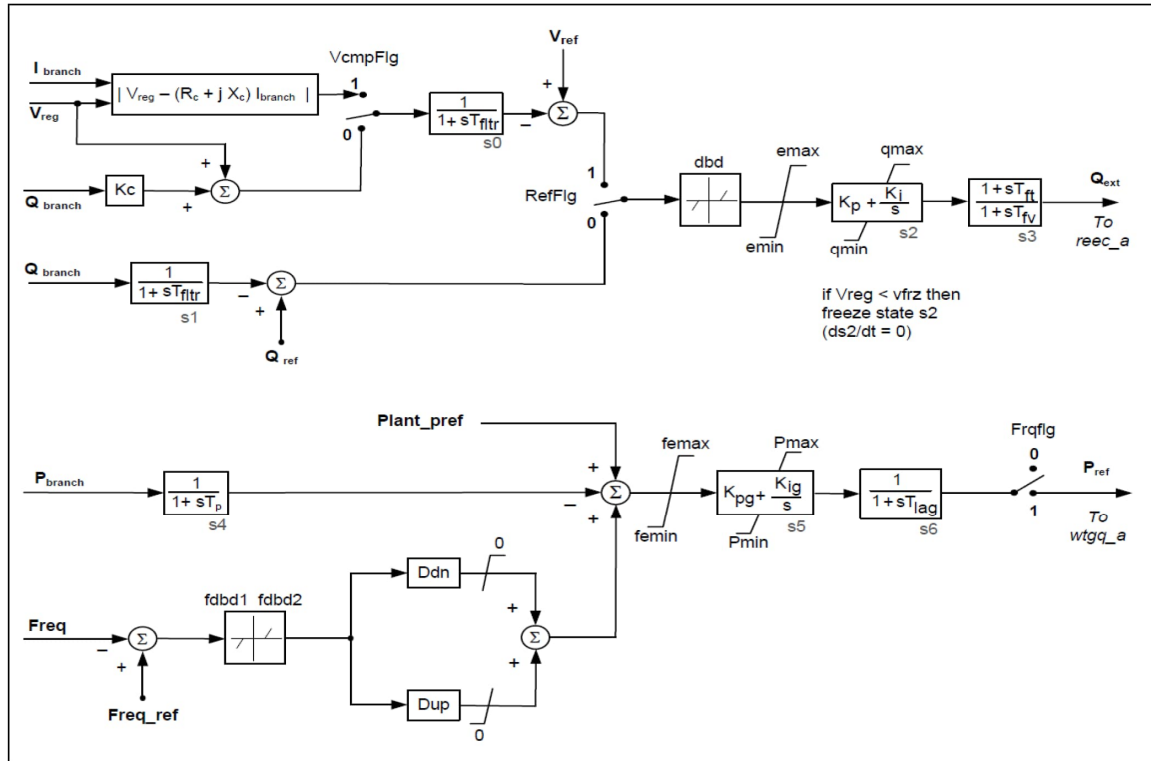

Figure 22 REPC_A model [6].

3.7 Inverter harmonic model

For harmonic analysis, the PV park is modeled with a harmonic Norton source. The harmonic study can be done in time domain, in which case **Use harmonic model for steady-state and time-domain simulations** must be checked or in the frequency domain with the frequency-scan simulation option, in which case **Use harmonic model for frequency-scan simulations**.

The harmonic currents are provided in percentage of the fundamental, for one inverter. The total park current is rescaled according to the number of inverters in service.

It is possible to automatically adjust the fundamental frequency current generated by each inverter and the harmonic current angles to match the load-flow results by checking Adjust fundamental frequency current to match Load-Flow results. When this box is checked, the I Angle input of the first line, which corresponds to the fundamental frequency current is adjusted to match the inverter current angle during the load-flow. The Fundamental frequency current magnitude is also adjusted to match the load-flow results. The fundamental frequency angle value is also added to the I Angle values of the other harmonics. Therefore, when this option is checked, the phase difference between the harmonic currents and the fundamental frequency current should be entered in the **I Angle** column.

4 References

- [1] "Proposal for new features for the renewable energy system generic models, Memo RES Modeling Updates 083120 Rev17.," [Online]. Available: <https://www.wecc.org/>.
- [2] "Proposed Changes to the WECC WT4 Generic Model for Type 4 Wind Turbine Generators," [Online]. Available: <https://www.wecc.org/>.
- [3] U. Karaagac, J. Mahseredjian, R. Gagnon, H. Gras, H. Saad, L. Cai, I. Kocar, A. Haddadi, E. Farantatos, S. Bu, K. W. Chan and L. Wang, "A Generic EMT-Type Model for Wind Parks With Permanent Magnet Synchronous Generator Full Size Converter Wind Turbines," *IEEE Power and Energy Technology Systems Journal*, vol. 6, no. 3, pp. 131-141, Sept. 2019.
- [4] A. Yazdani and R. Iravani, *Voltage-Sourced Converters in Power Systems: Modeling, Control, and Applications*, Wiley-IEEE Press, 2010.
- [5] "Converting REEC_B to REEC_A/D for Solar PV Generators," [Online]. Available: <https://www.wecc.org/>.
- [6] "WECC Wind Power Plant Dynamic Modeling Guid," [Online]. Available: <https://www.wecc.org/>.
- [7] EPRI, "Model User Guide for Generic Renewable Energy System Models," EPRI, 2018.
- [8] G.-C. Hsieh and J. C. Hung, "Phase-locked loop techniques. A survey," *IEEE Transactions on Industrial Electronics*, vol. 43, no. 6, pp. 609-615, 1996.
- [9] F. Blaabjerg, R. Teodorescu, M. Liserre and A. V. Timbus, "Overview of Control and Grid Synchronization for Distributed Power Generation Systems," *IEEE Transactions on Industrial Electronics*, vol. 53, no. 5, pp. 1398-1409, 2006.
- [10] "Transmission Provider Technical Requirements for the Connection of Power Plants to the Hydro-Quebec Transmission System," Hydro Quebec Transenergie, 2009.